



**TYPICAL**

# **TW1-28BL30/20**

**DOUBLE NEEDLE LONG ARM EXTRA HEAVY-DUTY  
COMPOUND FEED LOCKSTITCH SEWING MACHINE**

# **TW1-8BL30/20**

**SINGLE NEEDLE LONG ARM EXTRA HEAVY-DUTY  
COMPOUND FEED LOCKSTITCH SEWING MACHINE**

**OPERATION INSTRUCTION / PARTS MANUAL**

- Please don't adjust and repair the machine by non-professionals,except adjusting stitch.
- Specifications subject to change without notice

**TYPICAL SEWING MACHINE WANPING MACHINERY CO.,LTD.**

---

ADD: WANPING TOWN, WUJIANG CITY, JIANGSU

PROVINCE, CHINA

TEL: +86-512-63391278

FAX: +86-512-63391371

POST. CODE: 215223

[Http://www.typicalwpchina.com](http://www.typicalwpchina.com)

E-mail:[export@typicalwpchina.com](mailto:export@typicalwpchina.com)

Printed in DEC 2007

# CONTENTS

## **Operation instruction**

1、 Brief introduction	1
2、 Main specifications	1
3、 Installation and operation preparation	1
4、 Needle	1
5、 Lubrication	2
6、 Thread	
7、 Winding the bobbin thread	
8、 Installing the bobbin	3
9、 Threading the needle thread	
10、 Adjusting the tension of needle thread and bobbin thread	
11、 Adjusting the stitch length	4
12、 Adjusting the presser foot pressure	
13、 Reverse stitching	
14、 Adjusting the feeding	5
15、 Adjusting the feed dog	5
16、 Adjusting the timing between needle and hook	
17、 Adjusting the height of needle bar	6
18、 Adjusting the bobbin case opener	
19、 Adjusting the height of presser foot	6
20、 Adjusting the timing of vibrating presser foot	7
21、 Adjusting the presser foot movement amount	
22、 Adjusting the thread controller spring	
23、 Replacing the timing belt	8
24、 Safety clutch mechanism	
25、 Adjusting the bobbin thread winder	9
26、 Adjusting the hook oil amount	
27、 Installing the pedal	9

## **Parts manual**

1、 Casting components	10-12
2、 Upper shaft and thread take-up components	3 4
3、 needle bar rocking frame and upper feed components	5 6
4、 Feed components	
5、 Hook components	
6、 Thread tension components	21 22
7、 Accessories	3

2

## 1. Brief introduction

This series machines adopt sliding type take~up lever mechanism, compound feed with needle feed, bottom feed and alternating presser feet and link type feeding mechanism. Driven by timing belt and extra large hook is installed to form seam #301. These machines have the large working space and high lifting height of presser foot so it's suitable for sewing large products. Suitable for stitching tents, canvas, rubber products, heavy leather and furniture

## 3. Installation and operation preparation(Fig.1)

1. Before test and operation, the places need to lubricated must be oiled, during the testing time, the lubrication should be more frequently.
2. The turn direction of the hand wheel must face to the operator.
3. Please don't run at the max. speed for a new machine, the 90% of the max. speed is acceptable.
4. Before install the machine on the table, please first uninstall the two support rods

## 4. Needle(Fig.2)

1. The standard needle type is DY×3(24#~26#)  
The right need should be chosen according to the thread and materials to be sewn
2. Install the needle: turn the hand wheel to lift the needle bar to its highest position, loosen the needle set screw, fully insert the needle shank up to the bottom of needle bar (single needle) or needle clamp(double needle), for single needle machine, keep the long groove leftward; for double needle machine, keep the long grooves of the two needles opposite with each other, then tighten the needle set screw.

## 2. Main specifications

Model	TW1-28BL30	TW1-8BL30	TW1-28BL20	TW1-8BL20
Applications	Extra heavy weight materials			
Max Sewing Speed	800s.p.m		1000s.p.m	
Max Stitch length	10mm			
Needle Number	2	1	2	1
Presser foot lift height	20mm			
Needle	DY×3 24#~26#(standard26#)			
Working space	762mm×153mm		508mm×153mm	
Bed size	1100mm×230mm		846mm×230mm	
Motor power	550W, 4P			
Needle gauge	1/4"、1/2"、3/4"、1"、1 1/4"、1 1/2"、1 3/4"、2"、7/8" Standard 1/4" (for 2 needle machine)			

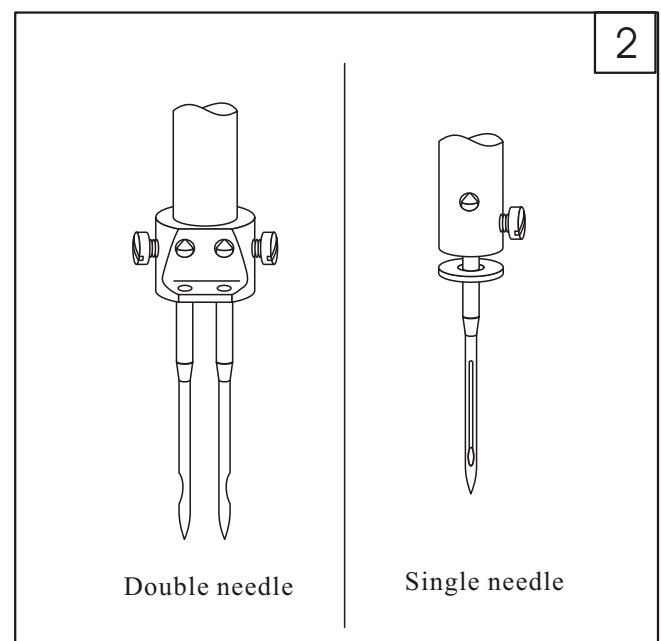
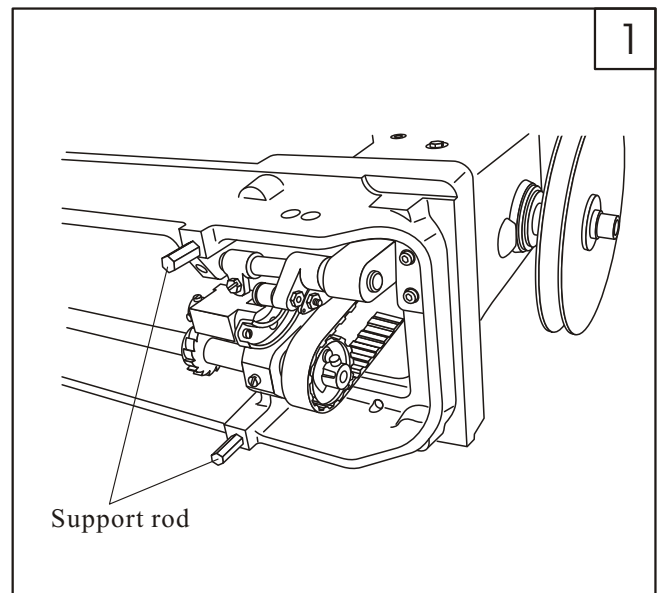

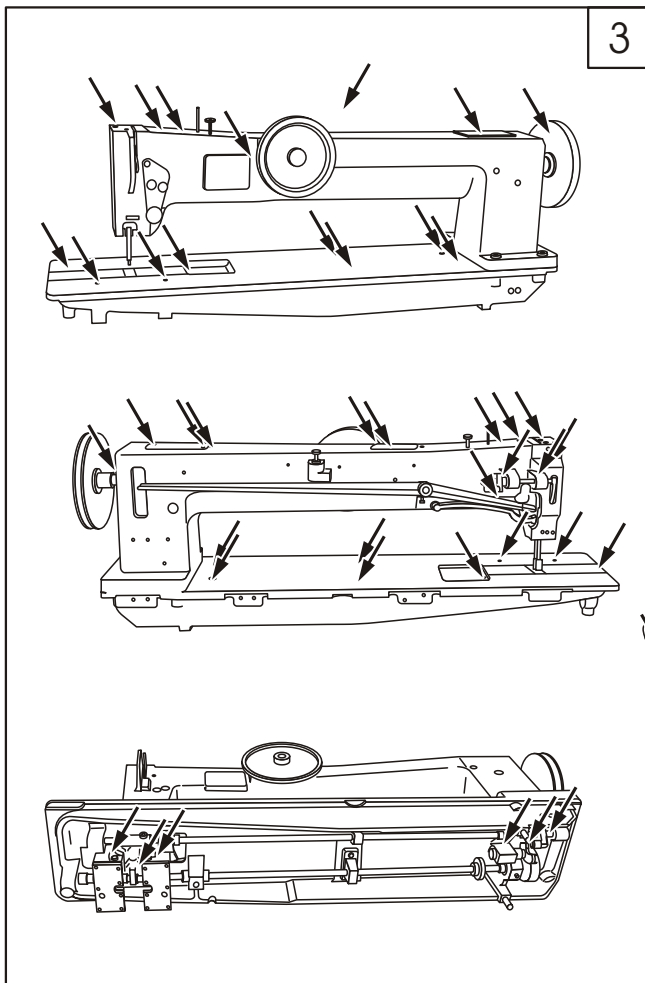

3

### 5. Lubrication(Fig.3)

1. Add 1-2 drops of oil in the places indicated by the arrows.
2. Put the oil indicator A out from the hook saddle, and fill oil in it until to the upper reference line.
3. Please lubricate at least twice every day if sewing continuously.

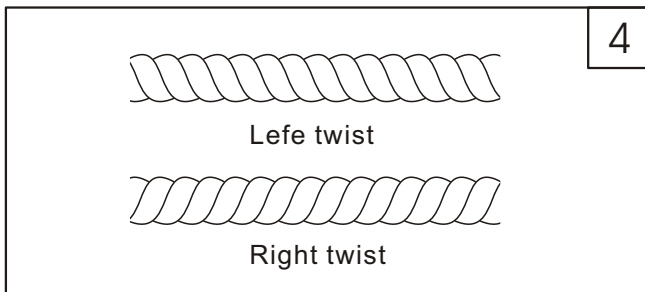
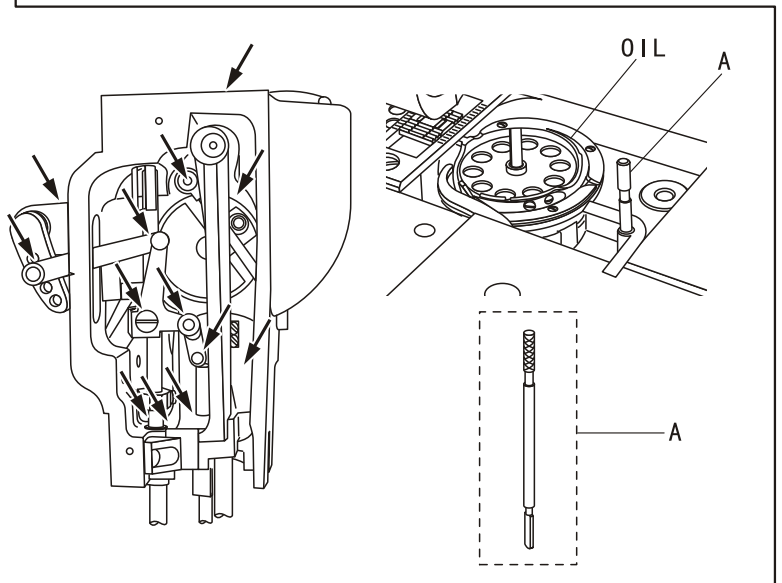

4

### 6. Thread(Fig.4)

Usually, the needle thread should be left twisted, but for double needle machine, the left needle thread should be right twisted.

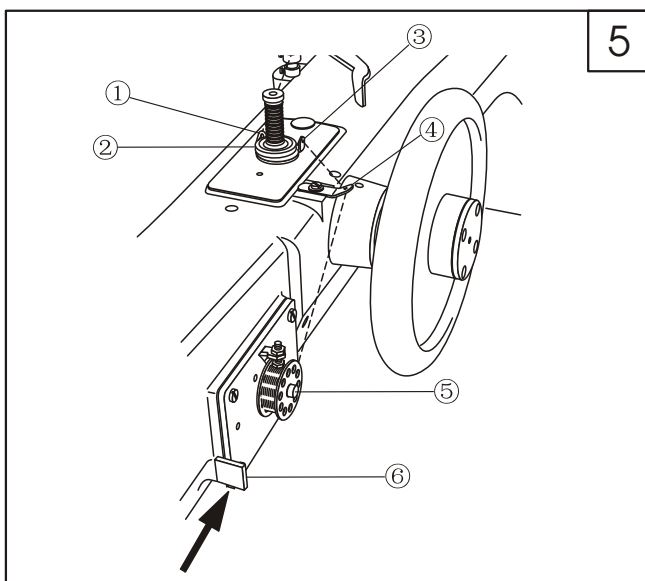

5

### 7. Winding the bobbin thread(Fig.5)

1. Drawing the bobbin thread through ① ② ③ ④, Wind thread several circles around bobbin and insert the bobbin into the shaft of bobbin winder ⑤.
2. put the winder lever ⑥ onto bobbin shown by arrow, then it can be automatic wound when sewing.

## 8. Installing the bobbin(Fig.6)

1. Open the slide plate ① and hook latch ②, then put the bobbin in the hook
2. Draw the bobbin thread ③ through hook lace ④ about 4-5cm, then lock the hook latch.
3. Close the slide plate.

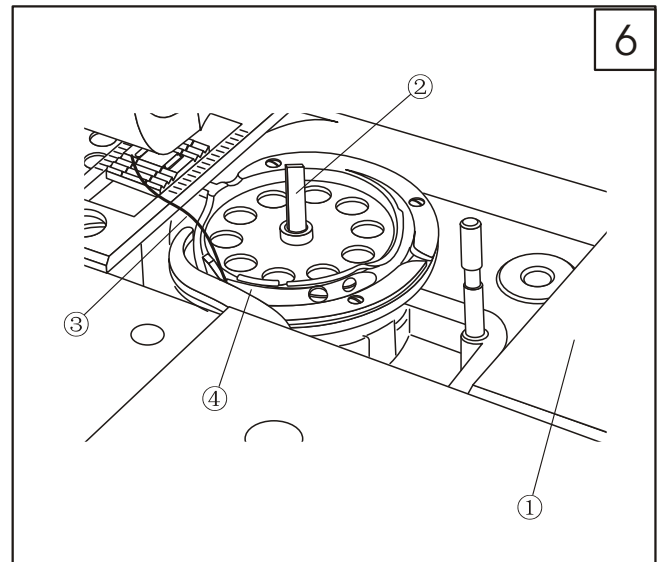

## 9. Threading the needle thread(Fig.7)

1. Passing the needle thread through thread guide pin ①, thread guide ②, thread tension ③, thread tension ④, lower thread guide rod ⑤, thread controller spring, upper thread guide ⑦, thread take-up lever ⑧, upper thread guide ⑦, lower thread guide ⑨, needle bar ⑩, and needle ⑪.
2. Hold the tip of needle thread by hand; turn the hand wheel to lower the needle bar, then lift it to its highest position, pull the needle thread and the bobbin thread will be drawn up accordingly, finally put the tip of needle thread and bobbin thread toward front under the presser foot.

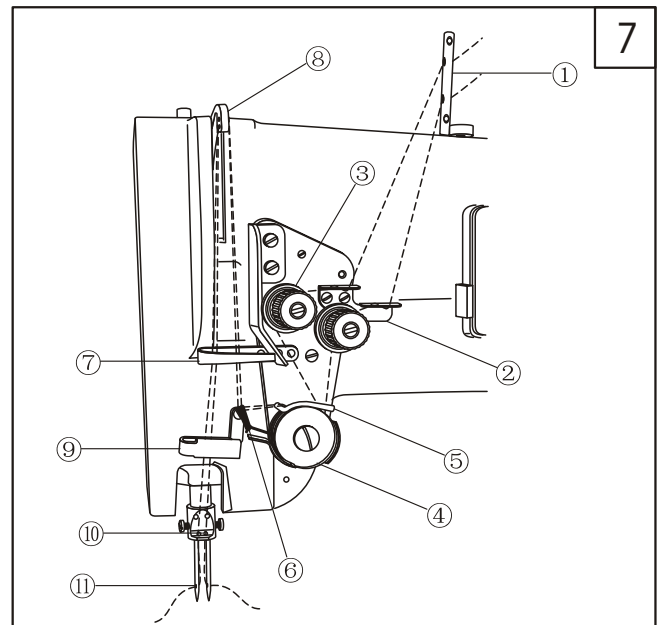

## 10. Adjusting the tension of needle thread and bobbin thread(Fig.8)

1. The tension of needle thread is controlled by the thread tension nut ①.
2. The tension of bobbin thread is adjusted by the Screw. Turn the screw clockwise to increase the tension and turn the screw counter-clockwise to decrease the tension

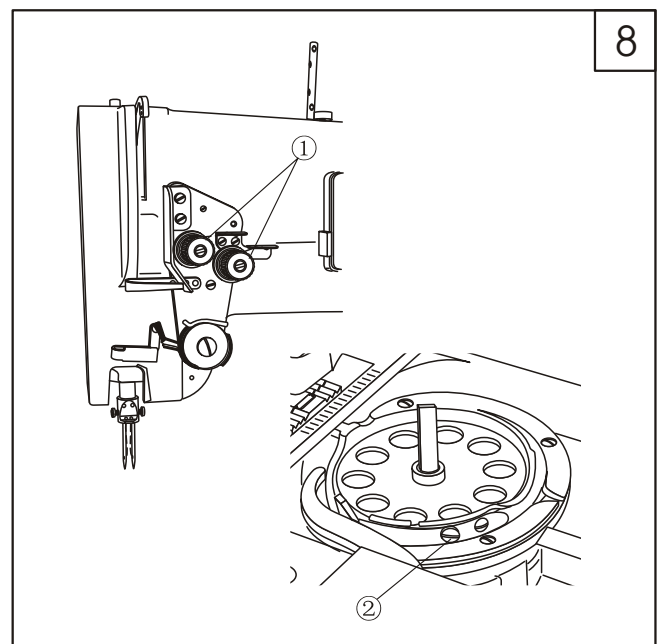

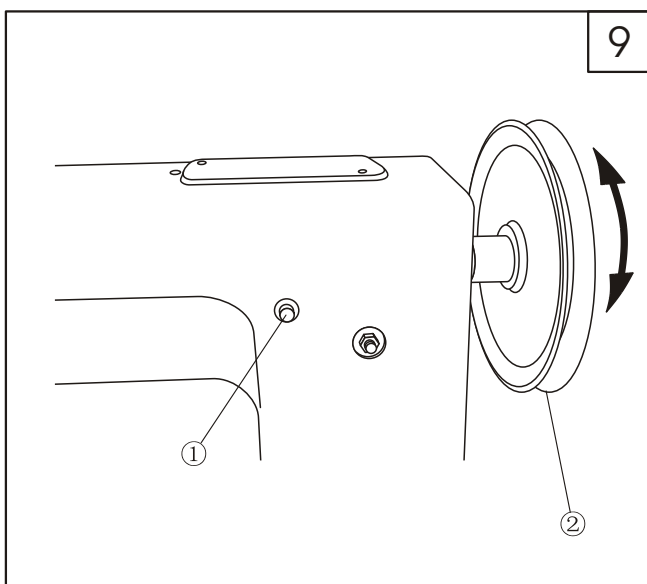

### 11. Adjusting the stitch length (Fig.9)

Put the stitch length button ① on the feed eccentric cam, press the button and turn the hand wheel ② slowly to adjust the stitch length.

Turn the hand wheel face to the operator to increase the length, on the contrary, to decrease the length.

When the required stitch length is obtained, release the button, and then begin to operate the machine

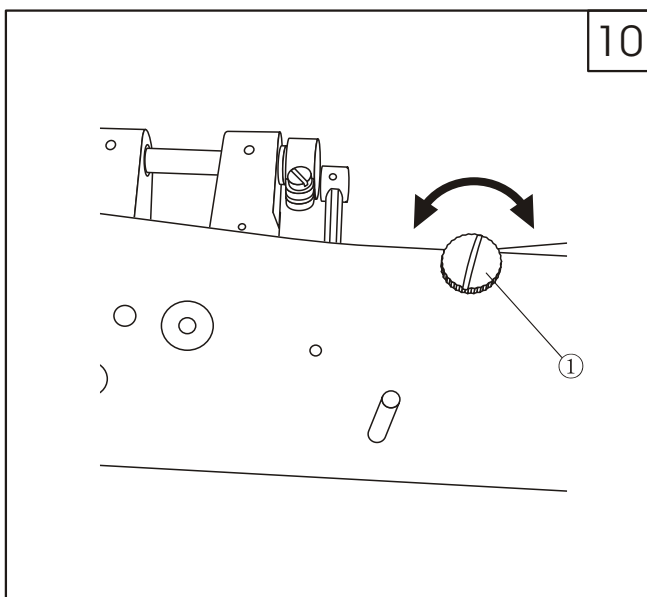

### 12. Adjusting the presser foot pressure (Fig.10)

Please turn the pressure regulating screw ① clockwise to increase the presser foot pressure, on the contrary, to decrease the pressure.

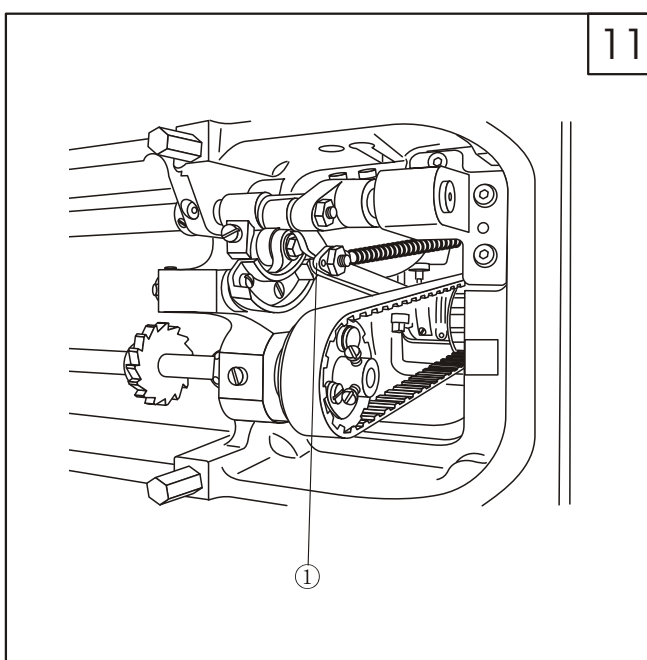

### 13. Reverse stitching (Fig.11)

Connect the reverse pedal with the block ①, when step on the pedal, the reverse stitching will be run.

## 14. Adjusting the feeding (Fig.12)

1. Adjust the feed eccentric cam to make the stitch length zero, at this position, the distance between vibrating presser bar ① and presser bar ② is 15.5mm (single needle) or 14.5mm (double needle). To adjust the stitch length by crank screw ③.
2. Usually, the position between feed dog and needle is: the needle should drop in the center of needle hole of feed dog. To adjust the position by screw ④.
3. After adjustment, please tighten the screws.
4. To adjust the eccentric cam ⑤ to control the max. stitch length.

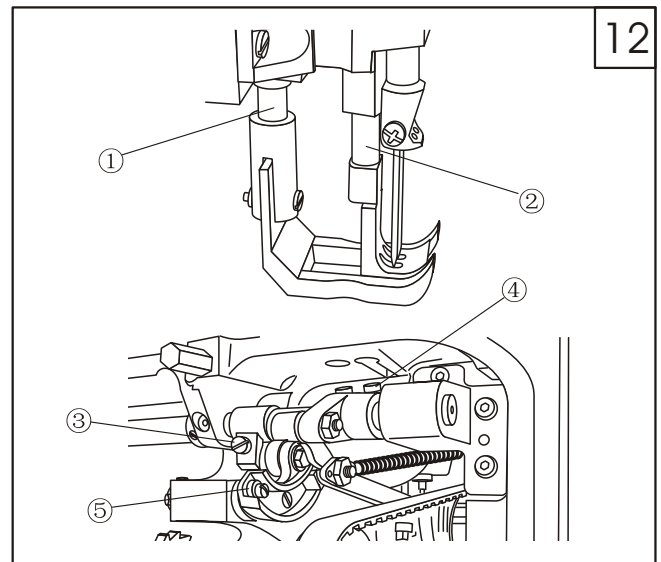

## 15. Adjusting the feed dog (Fig.13)

The maximum height of feed dog over the surface of needle plate is 1.3mm, To adjust the height by screw ①.

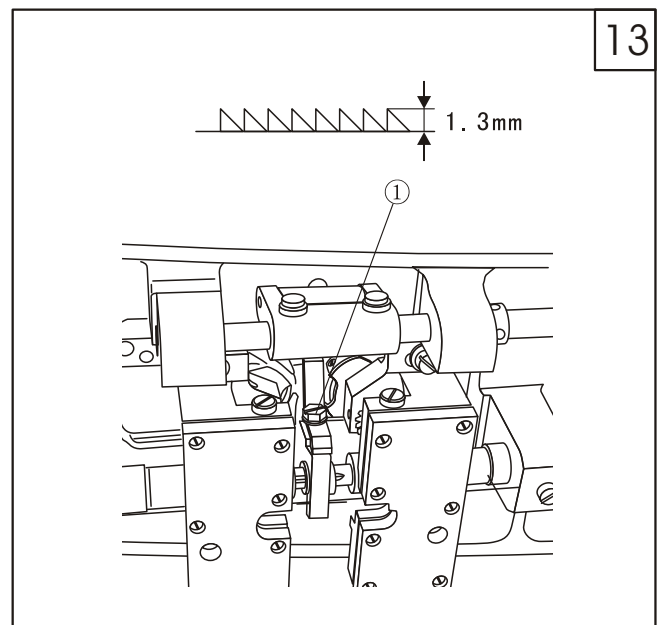

## 16. Adjusting the timing between needle and hook (Fig.14)

Set the feed eccentric with the button at no feeding position, and confirm the distance between vibrating presser bar and presser bar should be 15.5mm.

1. If the needle bar and hook are correctly timed, the point of the hook will be at the center of the needle when the needle raised  $3.8 \pm 0.5$ mm from the lowest point.

For the adjustment of timing, loosen the two screws ① for the hook driving gear, and tap this gear to the right or left in clearance of 2mm on the hook driving shaft until the point of the hook is at the center of the needle.

Tapping to the right gives an earlier hook timing, and to the left gives later hook timing.

Except the above case, to adjust in changing gear condition between hook driving gear ② and hook shaft gear ③.

Securely tighten the two screws for hook driving gear after finishing adjustment.

2. Normally, the clearance between hook point and scarf of needle is 0.02~0.1mm

- a. Loosen screw ④ ⑤;
- b. Move the hook saddle right or left until the hook point is as close to needle as possible, but without striking it;
- c. Tighten the two screws;
- d. Before adjustment, please be sure that the needle doesn't bend.

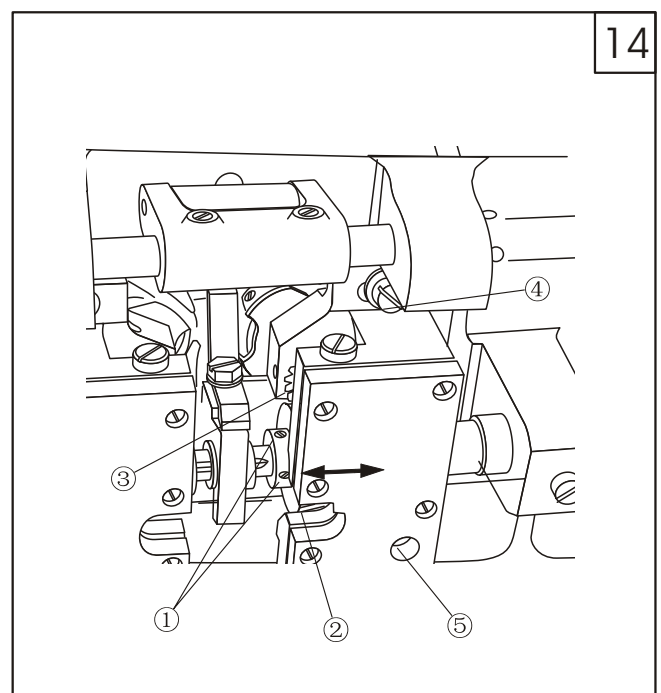

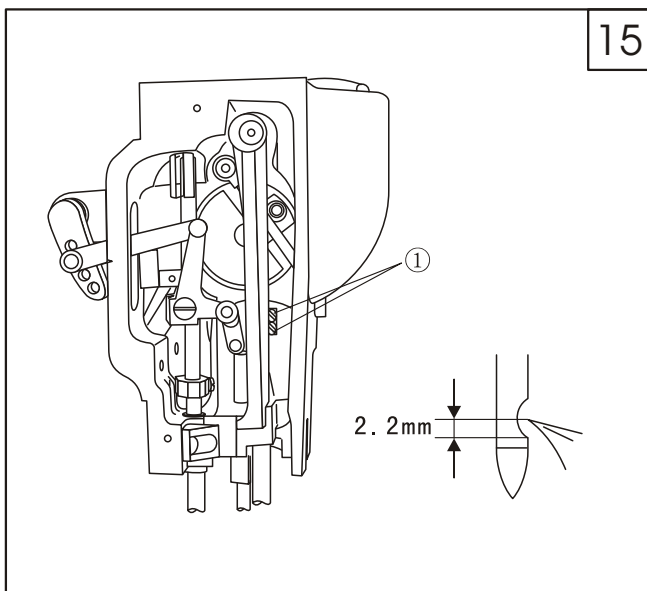

### 17. Adjusting the height of needle bar (Fig.15)

Normally, the clearance between top of the eye of needle and hook point is 2.2mm. In case the needle bar is incorrectly set, loose the needle bar setscrew ① and place the needle bar in correct position as required, and then tighten the screw ①.

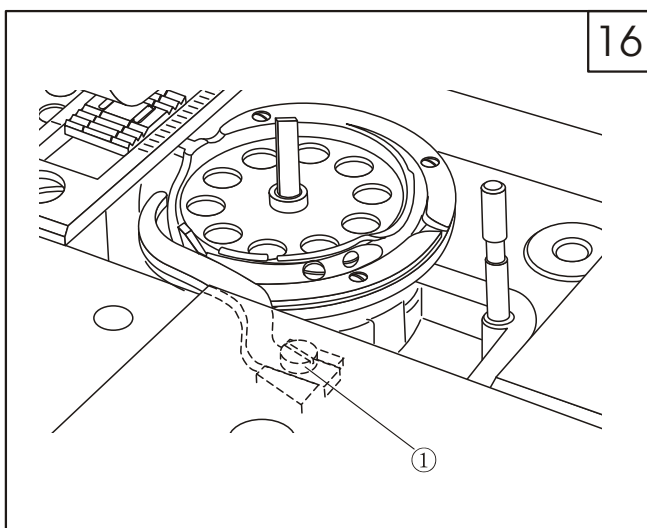

### 18. Adjusting the bobbin case opener (Fig.16)

1. Turn the hand wheel until the top of the opener ② is located at the distance from the needle plate;
2. In this position, adjust it so that the clearance between the inside edge of the opener and the top of the hook is about 0.3~0.8mm;
3. After adjustment, tighten the screw ①.

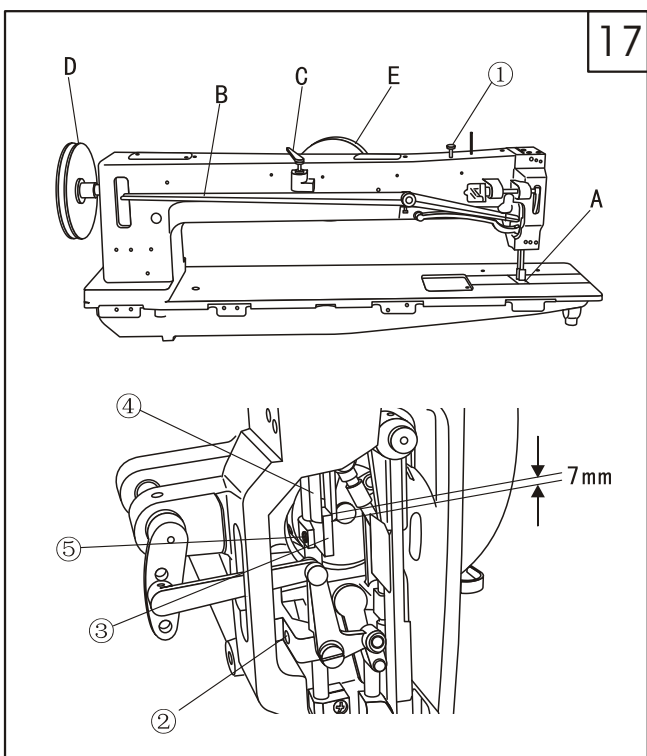

### 19. Adjusting the height of presser foot (Fig.17)

The distance between the surface of the needle plate (A) and the presser foot at stopped position is 19mm. When step on the lifting pedal, the stop lever (C) will be released by the lifting lever (B).

1. To change the relative lift of the presser feet, loosen the screw ① at the above condition.
2. The height of lift of the presser feet is adjustable by moving the screw of presser bar lifting bracket.
3. Normally, the distance between presser bar position guide bracket ③ and presser bar position guide ④ is 7mm.

Position of the vibrating presser foot to shift in left and right is to be adjusted by the screw ② for presser bar lifting bracket and the screw for presser bar position guide bracket.

## 20. Adjusting the timing of vibrating presser foot (Fig.18)

The amount of lift of the presser feet should be regulated according to the thickness of materials to be sewn.

The feet should lift just enough to clear the materials.

As a rule, the walking foot and presser foot should lift at the same height, but some grades of work may require that they lift an unequal height.

To change the relative lift of the presser feet, loosen the screw (A) for lifting rock shaft crank and move the vibrating presser bar upward or downward as required, then tighten the screw (A).

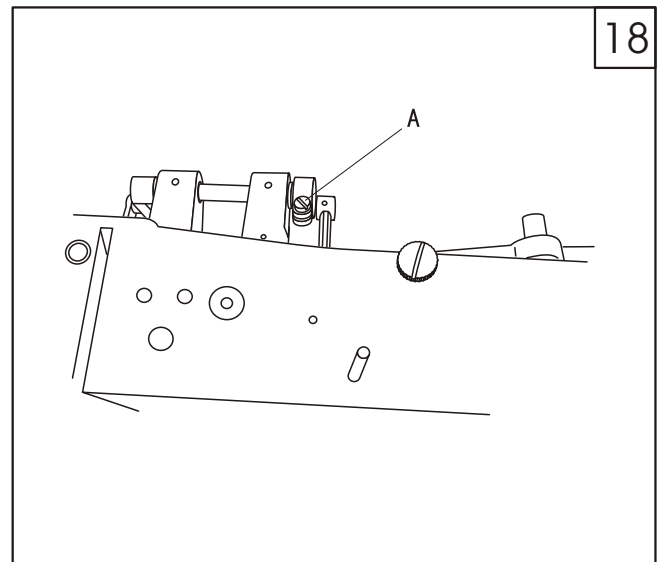

## 21. Adjusting the presser foot movement amount (Fig.19)

The lifting amount of presser foot and walking foot can be adjusted by the lifting bell crank link screw stud ①. To decrease the movement in setting the stud ① at the upper position, and to increase the movement in setting the stud ① at the lower position, after setting, tighten the stud ① with nut ②.

The clearance for the presser foot and walking foot are being adjusted at maximum, so that the clearance of them should be adjusted according to the materials to be sewn.

The timing position for the presser feet should be regulated by Fig.18.

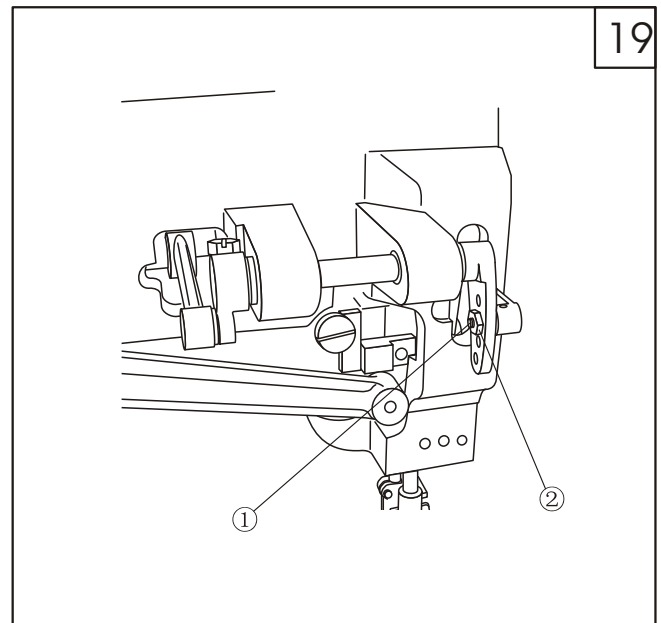

## 22. Adjusting the thread controller spring (Fig.20)

1. For more or less controller spring ① action on the thread, loosen the screw ② and turn the stop plate ③ to increase or decrease the action.

2. Adjusting the tension of controller spring: loosen the nut ④ and screw ⑤, turn the spring stud screw leftward with a screwdriver to increase the tension, or turn the stud screw rightward to decrease the tension, finally, tighten the screw ⑤.

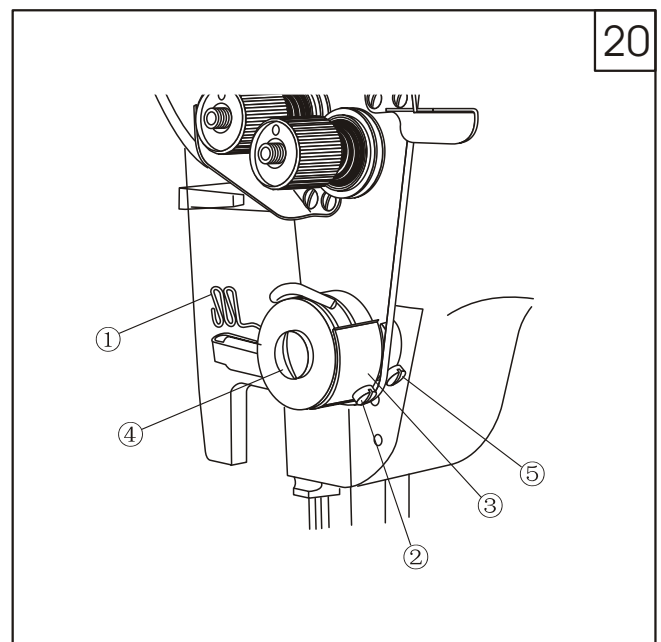

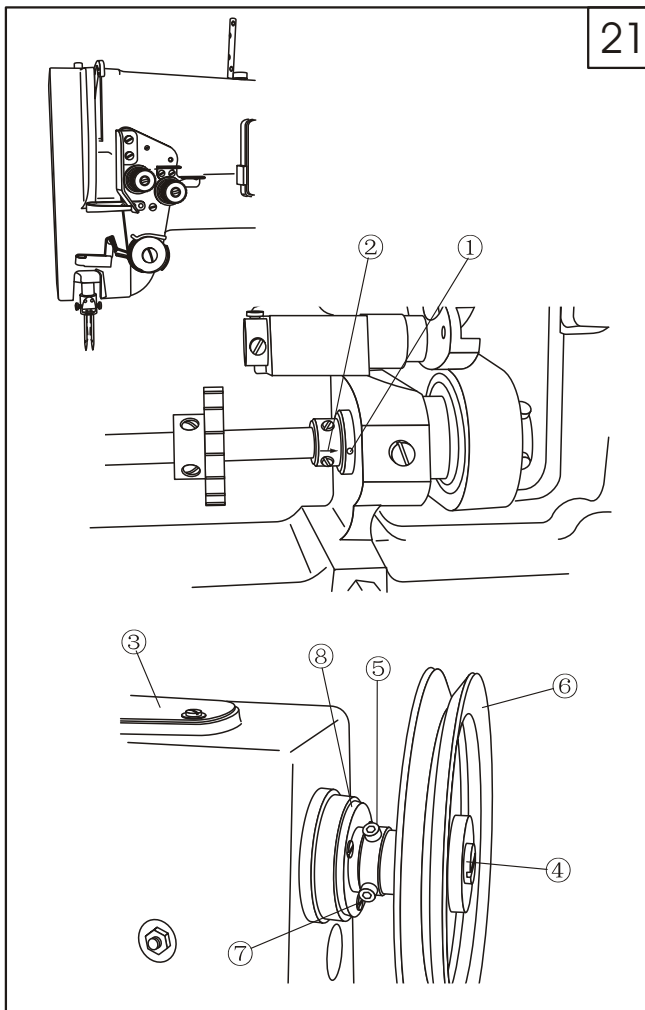

21

### 23.Replacing the timing belt(Fig.21)

A. When the timing belt removed from the pulley for adjustment and/or replacing spare parts, it should be replaced by the following processes:

1. Turn the hand wheel to lift the thread take-up lever to its highest position;
2. Turn the hook shaft with the fingers until the arrow mark on the hook driving shaft bush collar ② and the red point mark on the hook driving shaft bush ① are directly in line, then replace the belt over the upper and lower pulley.

B. Replacement of the timing belt when damaged

1. Remove the upper arm plate and oil reservoir ③
2. Loosen the hand wheel set screw ④ and other two screw ⑤, then remove the hand wheel ⑥;
3. Loosen the three screws ⑦ in the upper shaft bush and remove the bush ⑧;
4. Lift the belt up through the arm cap hole after removed the bush as far as possible and draw it out through the space normally occupied by the bush.
5. Replace the timing belt as opposite processes as above for removing it
6. Tighten all of the screws, so as to fit the upper shaft, free from looseness.

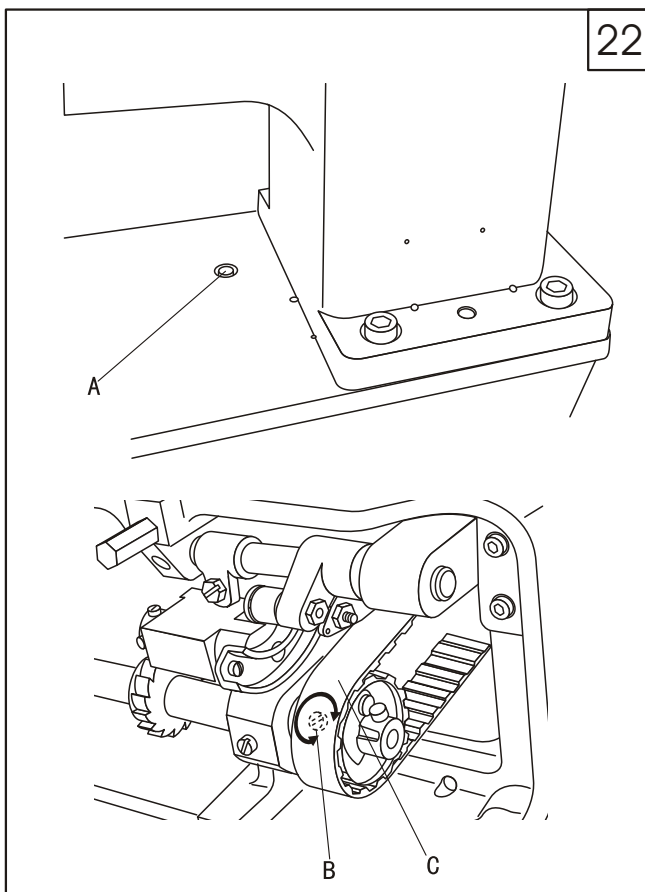

22

### 24.Safety clutch mechanism(Fig.22)

The safety clutch located on the right side of the lower timing pulley, it can prevent damage in the event of thread jamming in the hook by releasing the locking lever in the pulley.

1. Take out jammed thread from the hook;
2. To re-engage the clutch, press down the lock stud(A) by left hand, and turn the hand wheel backward slowly by right hand, then the safety clutch will be released.
3. In case easily releasing the safety clutch, adjust the pressure by the screw(B) after removed the timing belt(C). Turn the screw (B) clockwise to increase the pressure, and turn the screw (B) counter-clockwise to decrease the pressure

### 25.Adjusting the bobbin thread winder(Fig.23)

Adjust the volume of winding thread to the bobbin by the adjustment screw ①

Remove the plate ② on the front of the arm and adjust the slippage of the shaft for the winder by the winder driving gear ③ in the upper shaft to shifting right or left.

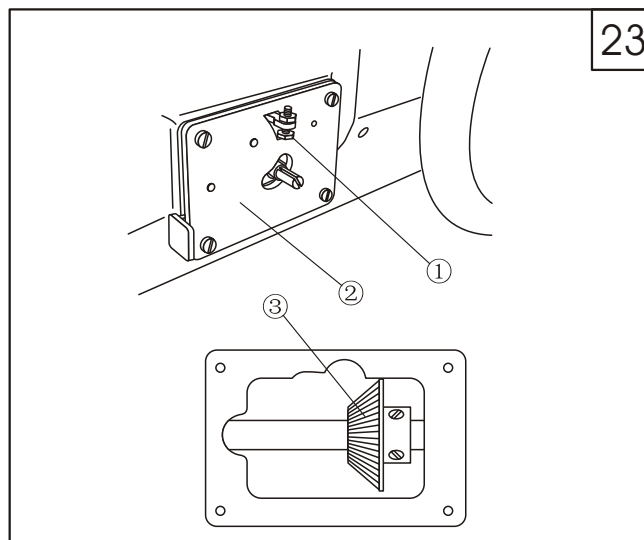

### 26.Adjusting the hook oil amount(Fig.24)

Loosen the screw ③ for the oil adjustment dial ② and adjust oil supply by truning the oil adjustment dial. When the point mark ① on the hook saddle is in line with the center line o the dial ②,the oil supply will be at the maximum level, when the point mark is at the vertical position of the center line of the dial, the oil supply will stop.

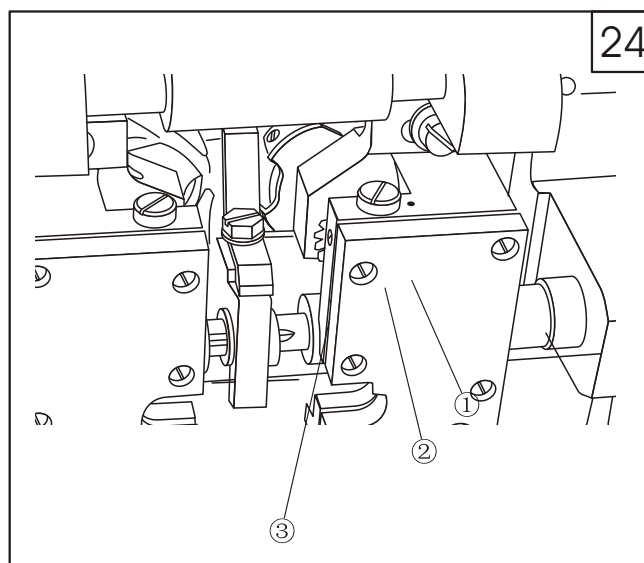

### 27.Adjusting the pedal(fig.25)

Construct the pedal set complete as shown in the Fig.25

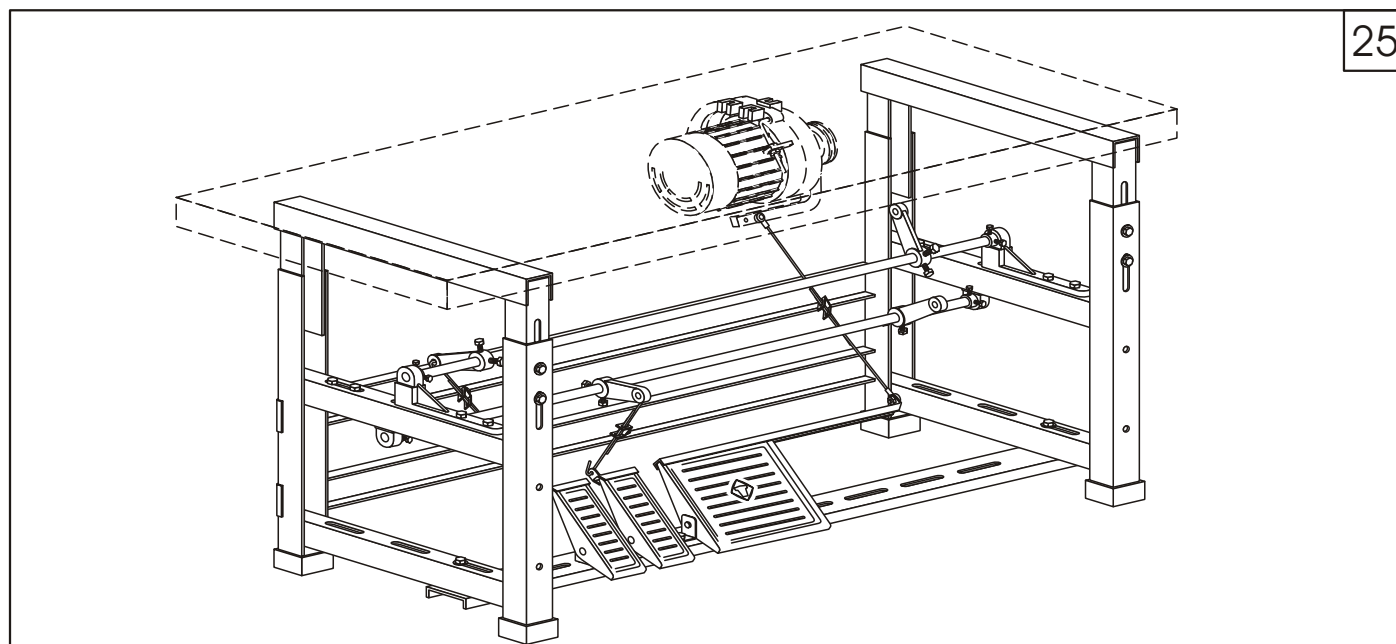

# 1.Casting components

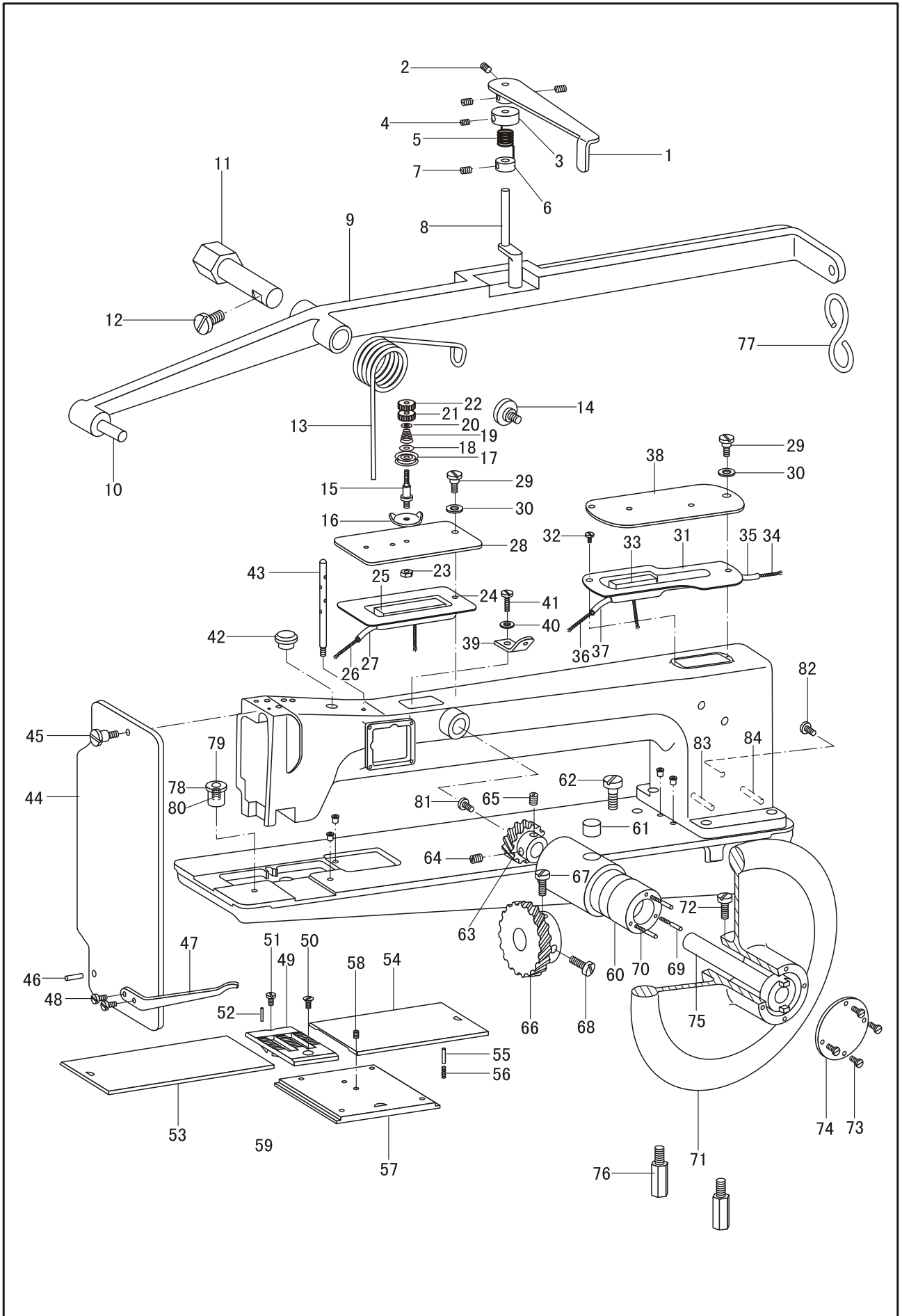

## 1.Casting components

No.	Part No.	Name of Parts	Qty.				Remark
			28-30	8-30	28-20	8-20	
1	14KT1-001	Foot lifter lifting handle	1	1	1	1	
2	22T1-011	Screw	3	3	3	3	SM11/64"X40X6
3	14KT1-002	Collar	1	1	1	1	
4	36T5-008E5	Screw	1	1	1	1	SM11/64"X40X5
5	14KT1-003	Spring	1	1	1	1	
6	14KT1-004	Collar	1	1	1	1	
7	22T2-017	Screw	1	1	1	1	SM1/8"X44X5
8	14KT1-005	Foot lifter lifting latch	1	1	1	1	
9	14KT1-006	Foot lifter lifting lever	1	1	-	-	
	15KT1-001	Foot lifter lifting lever	-	-	1	1	
10	14KT1-007	Pin	1	1	1	1	
11	14KT1-008	Stud	1	1	1	1	
12	22WF3-011	Screw	1	1	1	1	SM1/4"X28X16.5
13	14KT1-009	Spring	1	1	1	1	
14	14KT1-010	Screw	1	1	1	1	SM17/64"X32X8.1
15	14KT1-011A	Tension stud	1	1	1	1	
16	14KT1-011B	Thread guide	1	1	1	1	
17	14KT1-011C	Tension disc	2	2	2	2	
18	14KT1-011D	Tension release disc	1	1	1	1	
19	14KT1-011E	Tension spring	1	1	1	1	
20	14KT1-011F	Washer	1	1	1	1	
21	14KT1-011G	Nut	1	1	1	1	
22	14KT1-011H	Nut	1	1	1	1	
23	13WF2-052	Nut	1	1	-	-	SM11/64"X40
24	14KT1-012	Lubrication oil cup	1	1	-	-	
25	14KT1-013	Oil pad	1	1	-	-	
26		Oil wick	1	1	-	-	L=200mm
27		Oil Tube	1	1	-	-	φ5Xφ3X85
28	14KT1-014	Cover	1	1	-	-	
29	16WF2-022	Screw	2	2	1	1	SM3/16"X28X6.5
30	16WF2-023	Washer	2	2	1	1	
31	14KT1-015	Lubrication oil cup	1	1	1	1	
32	72WF1-024	Screw	1	1	1	1	SM1/8"X44X7
33		Oil pad	1	1	1	1	45X15X10
34		Oil wick	1	1	1	1	L=200mm
35		Oil tube	1	1	1	1	φ5xφ3x80
36		Oil wick	1	1	1	1	L=300mm
37		Oil tube	1	1	1	1	φ5Xφ3X125
38	14KT1-016	Cover	1	1	1	1	
39	13WF6-027	Bobbin Winder thread guide	1	1	1	1	
40		Washer	1	1	1	1	GB848-85-4
41	61-04-01/B316	Screw	1	1	1	1	SM9/64"X40X8
42	16WF2-003	Rubber plug	1	1	1	1	
43	14KT1-017	Thread guide	1	1	1	1	
44	14KT1-018	Face plate	1	1	1	1	
45	16WF2-009	Screw	1	1	1	1	SM1/8"X44X7
46	16WF2-010	Pin	1	1	1	1	
47	14KT1-019	Thread guide	1	1	1	1	
48	13WF6-008	Screw	2	2	2	2	SM1/8"X40X3.3
49	14KT1-020	Needle plate	1	-	1	-	
	18KT1-001	Needle plate	-	1	-	1	
50	1WF1-034	Screw	1	2	1	2	SM11/64"X40X8.3
51	1WF1-036	Screw	1	-	1	-	SM9/64"X40X5.4
52	1WF1-037	Pin	1	-	1	-	
53	14KT1-021	Slide plate(L)	1	-	1	-	
	18KT1-002	Slide plate(L)	-	1	-	1	
54	14KT1-022	Slide plate(R)	1	-	1	-	
	18KT1-003	Slide plate(R)	-	1	-	1	
55	88WF1-003	Pin	1	1	1	1	
56	21WF3-046	Spring	1	1	1	1	
57	14KT1-023	Slide plate(front)	1	-	1	-	
58	21WF4-064	Screw	1	-	1	-	SM13/64"X32X4.3
59	93WF1-012	Spring	1	-	1	-	

## 1.Casting components

No.	Part No.	Name of Parts	Qty.				Remark
			28-30	8-30	28-20	8-20	
60	14KT1-024	Bushing	1	1	-	-	
61	16WF1-025	Oil felt	1	1	-	-	
62	7KT4-024	Screw	1	1	-	-	SM17/64"X32X17.5
63	14KT1-025	Gear (small)	1	1	-	-	
64	22WF4-002	Screw	1	1	-	-	SM1/4"X40X5.5
65	21WF1-033	Screw	1	1	-	-	SM1/4"X40X5.5
66	14KT1-026	Gear (big)	1	1	-	-	
67	14KT1-027	Screw	1	1	-	-	SM1/4"X40X13
68	14KT1-028	Screw	1	1	-	-	SM1/4"X40X13
69	14KT1-029	Pin	3	3	-	-	
70	14KT1-030	Spring	3	3	-	-	
71	14KT1-031	Hand wheel	1	1	-	-	
72	14KT1-032	Screw	2	2	-	-	SM1/4"X32
73	22T2-019	Screw	4	4	-	-	SM11/64"X40X8
74	14KT1-033	Hand wheel engaging plate	1	1	-	-	
75	14KT1-034	Hand wheel shaft	1	1	-	-	
76	14KT1-035	Machine supporting bolt	3	3	3	3	606082
77		Chain hook	1	1	1	1	
78	16WF2-004	Ball oiler	5	5	5	5	
79	16WF2-005	Ball	5	5	5	5	
80	16WF2-006	Spring	5	5	5	5	SM17/64"X24X11
81	14KT1-036	Screw	1	1	1	1	GB818-85 M4X4
82		Screw	1	1	1	1	
83	14KT1-040A	Oil tube (ling)	1	1	1	1	
84	14KT1-040B	Oil tube (short)	1	1	1	1	

## 2.Upper shaft and thread take-up componets

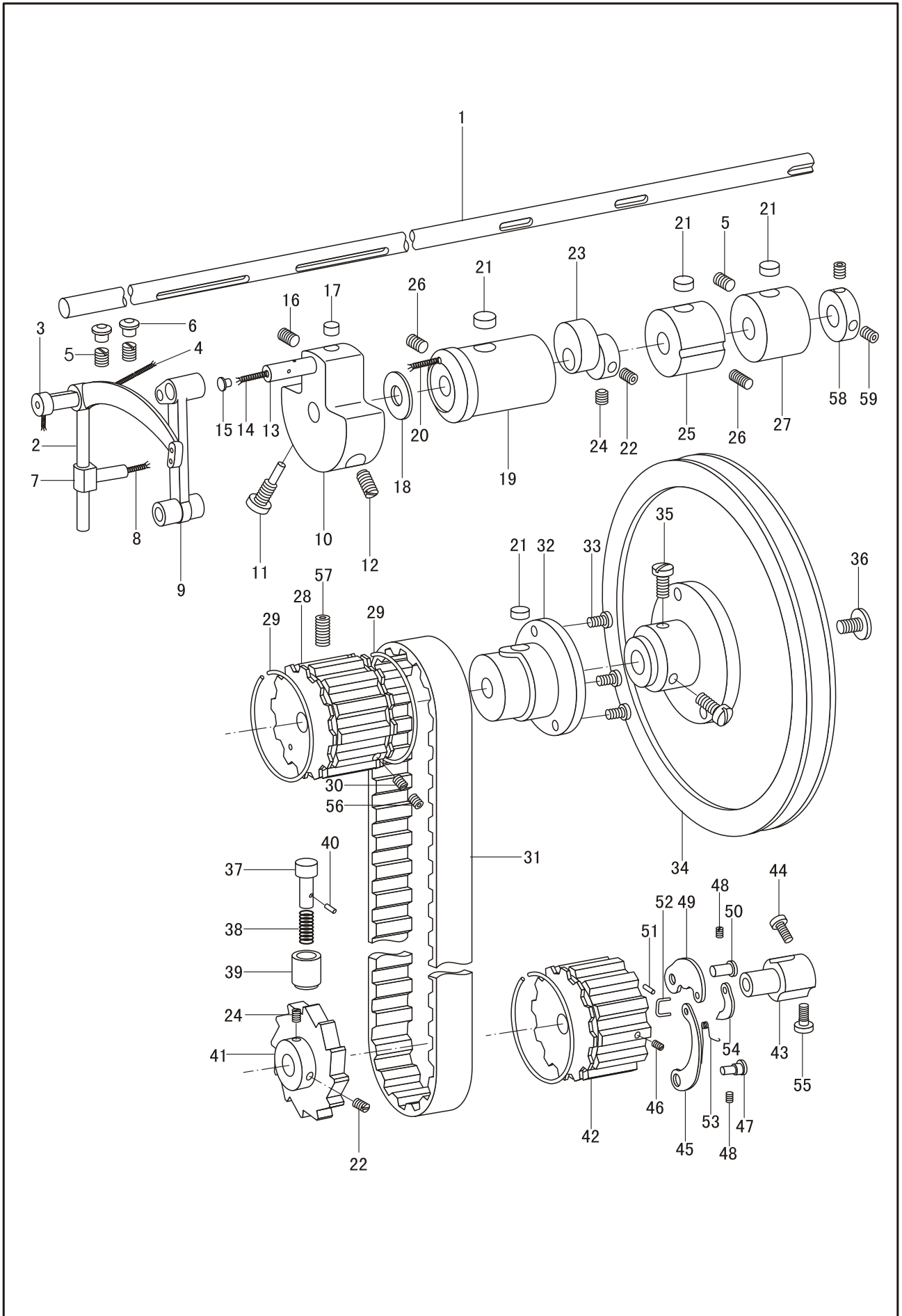

## 2.Upper shaft and thread take-up componets

No.	Part No.	Name of Parts	Qty.				Remark
			28-30	8-30	28-20	8-20	
1	14KT2-001	Upper shaft	1	1	-	-	
	15KT2-001	Upper shaft	-	-	1	1	
2	14KT2-002	Thread take-up lever	1	1	1	1	
3	14KT2-003	Hinge stud	1	1	1	1	
4		Oil wick	1	1	1	1	L=200mm
5	16WF1-004	Screw	3	3	3	3	SM17/64"X32X20
6	14KT2-004	Rubber plug	2	2	2	2	
7	14KT2-005	Take-up lever driving stud	1	1	1	1	
8		Oil wick	1	1	1	1	L=20mm
9	14KT2-006	Needle bar connecting link	1	1	1	1	
10	14KT2-007	Needle bar crank	1	1	1	1	
11	14KT2-018	Screw	1	1	1	1	SM9/32"X28
12	21WF1-012	Screw	2	2	2	2	SM9/32"X28
13	16WF1-015	Needle ba crank stud	1	1	1	1	
14		Oil wick	1	1	1	1	L=45mm
15	88WF2-003	Rubber plug	1	1	1	1	
16	14KT2-008	Screw	1	1	1	1	SM17/64"X24X6.5
17	14KT2-023	Screw	1	1	1	1	SM17/64"X24X3.5
18	16WF1-021	Washer	1	1	1	1	
19	14KT2-009	Upper shaft bushing(L)	1	1	1	1	
20		Oil wick	1	1	1	1	L=45mm
21	16WF1-025	Oil felt	4	4	4	4	φ17X10
22	16WF1-054	Screw	2	2	2	2	SM1/4"X32X8
23	14KT2-010	Feed driving eccentric	1	1	1	1	
24	16WF1-053	Screw	2	2	2	2	SM1/4"X32X7
25	14KT2-011	Central bushing(L)	1	1	1	1	
26	16WF3-025	Screw	2	2	2	2	SM17/64"X32X11
27	14KT2-012	Central bushin(R)	1	1	1	1	
28	22WF1-043	Belt pulley	1	1	1	1	
29	16WF1-043	Belt pulley spring flange	3	3	3	3	
30	14KT2-021	Screw	1	1	1	1	SM1/4"X28X11
31	14KT2-013	Timing belt	1	1	1	1	
32	14KT2-014	Upper shaft bushing(R)	1	1	1	1	
33	21WF1-062	Screw	3	3	3	3	SM3/1"X32X9.5
34	14KT2-015	Hand wheel	1	1	1	1	
35	14KT2-022	Screw	2	2	2	2	SM17/64"X24X16
36	14KT1-036	Screw	1	1	1	1	SM17/64"X24X11
37	22WF1-038	Lock button	1	1	1	1	
38	16WF3-046	Spring	1	1	1	1	
39	22WF1-040	Socket	1	1	1	1	GB91-86 1.6X10
40		Stop	1	1	1	1	
41	14KT2-016	Safety clutch pulley	1	1	1	1	
42	14KT2-017	Safety clutch collar	1	1	1	1	
43	22WF1-011	Screw	1	1	1	1	SM1/4"X32X10.5
44	14KT2-024	Locking spring lever	1	1	1	1	
45	22WF1-013	Screw	1	1	1	1	SM5/32"X40X3.6
46	14KT2-019	Stud	1	1	1	1	
47	14KT2-020	Screw	2	2	2	2	SM7/32"X32X7
48	22WF1-020	Safety clutch locking lever	1	1	1	1	
49	22WF1-018	Stud	1	1	1	1	
50	22WF1-019	Pin	1	1	1	1	GB91-86 1.2X8
51		Connecting link	1	1	1	1	
52	22WF1-017	Spring	1	1	1	1	
53	22WF1-014	Latch	1	1	1	1	
54	22WF1-016	Screw	1	1	1	1	SM1/4"X32X10.5
55	22WF1-052	Screw(short)	1	1	1	1	SM1/4"X28X6
56	22WF1-045	Screw(long)	1	1	1	1	SM1/4"X28X20
57	22WF1-046	Collar	1	1	1	1	
58	037509	Screw	1	1	1	1	SM1/4"X32X8
59	380640	Screw	2	2	2	2	

### 3. Needle bar rocking frame and upper feed components

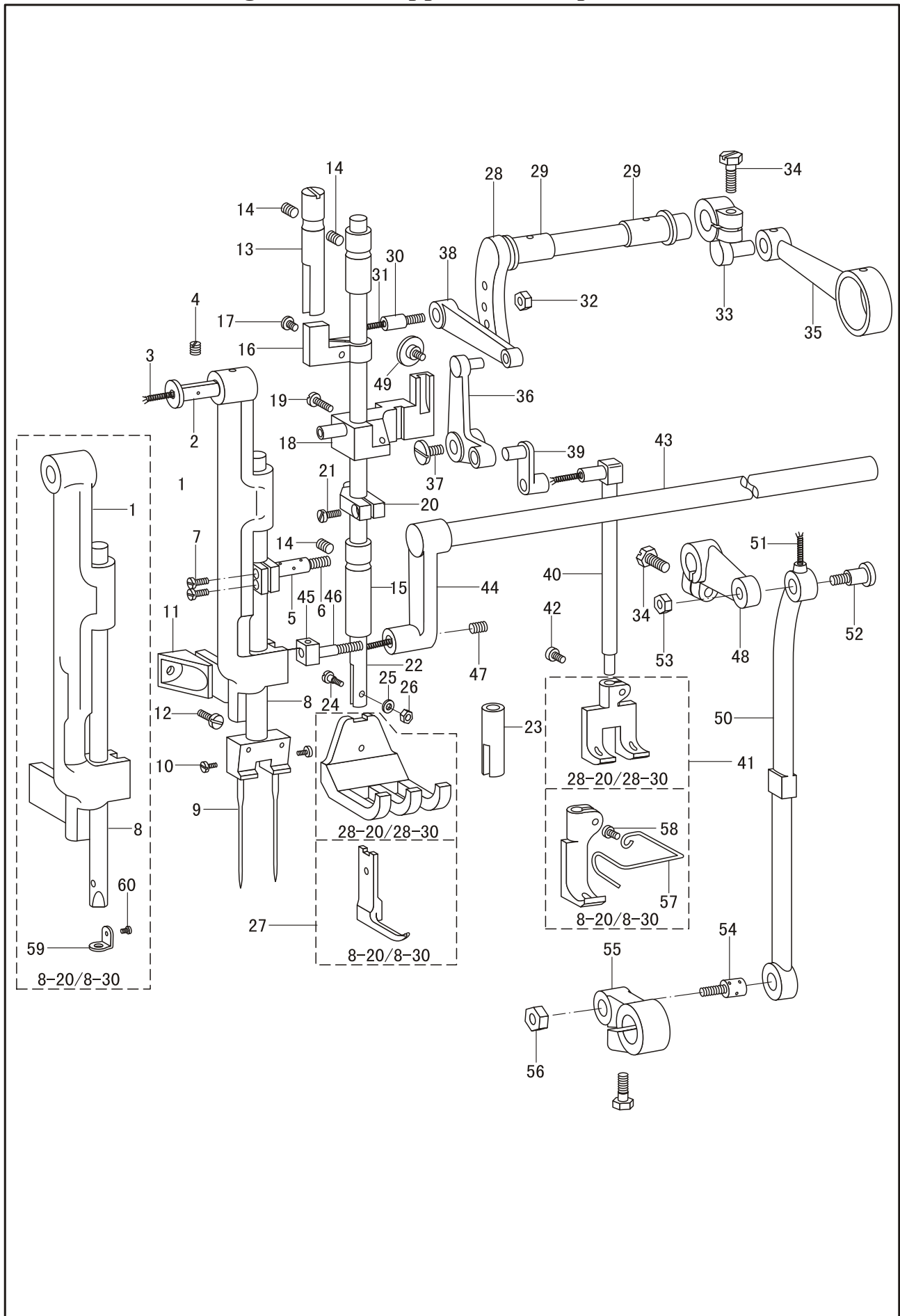

### 3. Needle bar rocking frame and upper feed components

No.	Part No.	Name of Parts	Qty.				Remark
			28-30	8-30	28-20	8-20	
1	14KT3-001	Needle bar rocking frame	1	-	1	-	
	18KT2-003	Needle bar rocking frame	-	1	-	1	
2	14KT3-002	Stud	1	1	1	1	
3		Oil wick	1	1	1	1	L=30mm
4	14KT3-003	Screw	1	1	1	1	SM17/64"X32X19.5
5	14KT3-004	Needle bar connector	1	1	1	1	
6		Oil wick	1	1	1	1	L=40mm
7	21WF4-005	Screw	2	2	2	2	SM9/64"X40X9
8	14KT3-005	Needle bar	1	-	1	-	
	18KT2-001	Needle bar	-	1	-	1	
9	14KT3-038	Needle	2	1	2	1	DYX3 24~26#
10	21WF3-031	Screw	2	1	2	1	SM3/16"X32X6
11	14KT3-006	Position bracket	1	1	1	1	
12	13WF2-047	Screw	1	1	1	1	SM11/64"X32X9
13	14KT3-007	Presser bar position guide	1	1	1	1	
14	16WF3-025	Screw	3	3	3	3	SM17/64"X32X11
15	14KT3-008	Presser bar bushing	2	2	2	2	
16	14KT3-009	Position guide lever	1	1	1	1	
17	16WF4-022	Screw	1	1	1	1	SM9/64"X40X6.5
18	14KT3-010	Presser bar lifting bracket	1	1	1	1	
19	16WF2-033	Screw	1	1	1	1	SM11/64"X40X14
20	14KT3-011	Presser bar spring bracket	1	1	1	1	
21	21WF6-011	Screw	1	1	1	1	SM3/16"X32X13.7
22	14KT3-012	Presser bar	1	1	1	1	
23	14KT3-013	Holder	1	1	1	1	
24	14KT3-014	Screw	1	1	1	1	SM0.1339" (3.4) X36
25		Washer	1	1	1	1	GB848-85-4
26	14KT3-021	Nut	1	1	1	1	SM0.1339" (3.4) X36
27	14KT3-015	Presser foot	1	-	1	-	
	18KT2-002	Presser foot	-	1	-	1	
28	14KT3-016	Lifting rock shaft	1	1	1	1	
29	22WF5-013	Bushing	2	2	2	2	
30	14KT3-017	Screw stud	1	1	1	1	
31		Oil wick	1	1	1	1	L=30mm
32	22WF5-016	Nut	1	1	1	1	SM1/4"X28
33	14KT3-018	Lifting eccentric	1	1	1	1	
34	14KT2-022	Screw	4	4	4	4	SM17/64"X24X16
35	14KT3-019	Lifting eccentric connection	1	1	1	1	
36	14KT3-020	Lifting bell crank	1	1	1	1	
37	22WF5-027	Screw	1	1	1	1	SM11/64"X40X8
38	14KT3-022	Link	1	1	1	1	
39	14KT3-023	Vibrating presser bar link	1	1	1	1	
40	14KT3-024	Vibrating presser bar	1	1	1	1	
41	14KT3-025	Walking foot	1	-	1	-	
	18KT2-004	Walking foot	-	1	-	1	
42	14KT3-026	Screw	1	1	1	1	SM11/64"X40X7.5
43	14KT3-027	Rocking shaft	1	1	-	-	
	15KT3-001	Rocking shaft	-	-	1	1	
44	14KT3-028	Link	1	1	1	1	
45	14KT3-029	Slide block	1	1	1	1	
46	14KT3-030	Slide block stud	1	1	1	1	
47	22WF1-020	Screw	1	1	1	1	SM7/32"X32X7
48	14KT3-031	Crank	1	1	1	1	
49	14KT1-010	Screw	1	1	1	1	SM17/64"X32X8.1
50	14KT3-033	Crank connection	1	1	1	1	
51		Oil wick	1	1	1	1	L=15mm
52	14KT3-034	Screw	1	1	1	1	SM17/64"X24X12.5
53	14KT4-034	Nut	1	1	1	1	SM17/64"X24
54	14KT3-035	Screw	1	1	1	1	SM0.3091"X20
55	14KT3-036	Feed reverse crank	1	1	1	1	
56	14KT4-035	Nut	1	1	1	1	SM0.3091"X20
57	14KT3-037	Finger guard	1	1	1	1	
58	22T2-017	Screw	1	1	1	1	SM1/8"X44X4.5
59	18KT2-005	Needle bar thread guide	-	1	-	1	
60	20T1-013F3	Screw	-	1	-	1	SM3/32"X56X2.5
61	803177	Pin	1	1	1	1	

# 4.Feed components

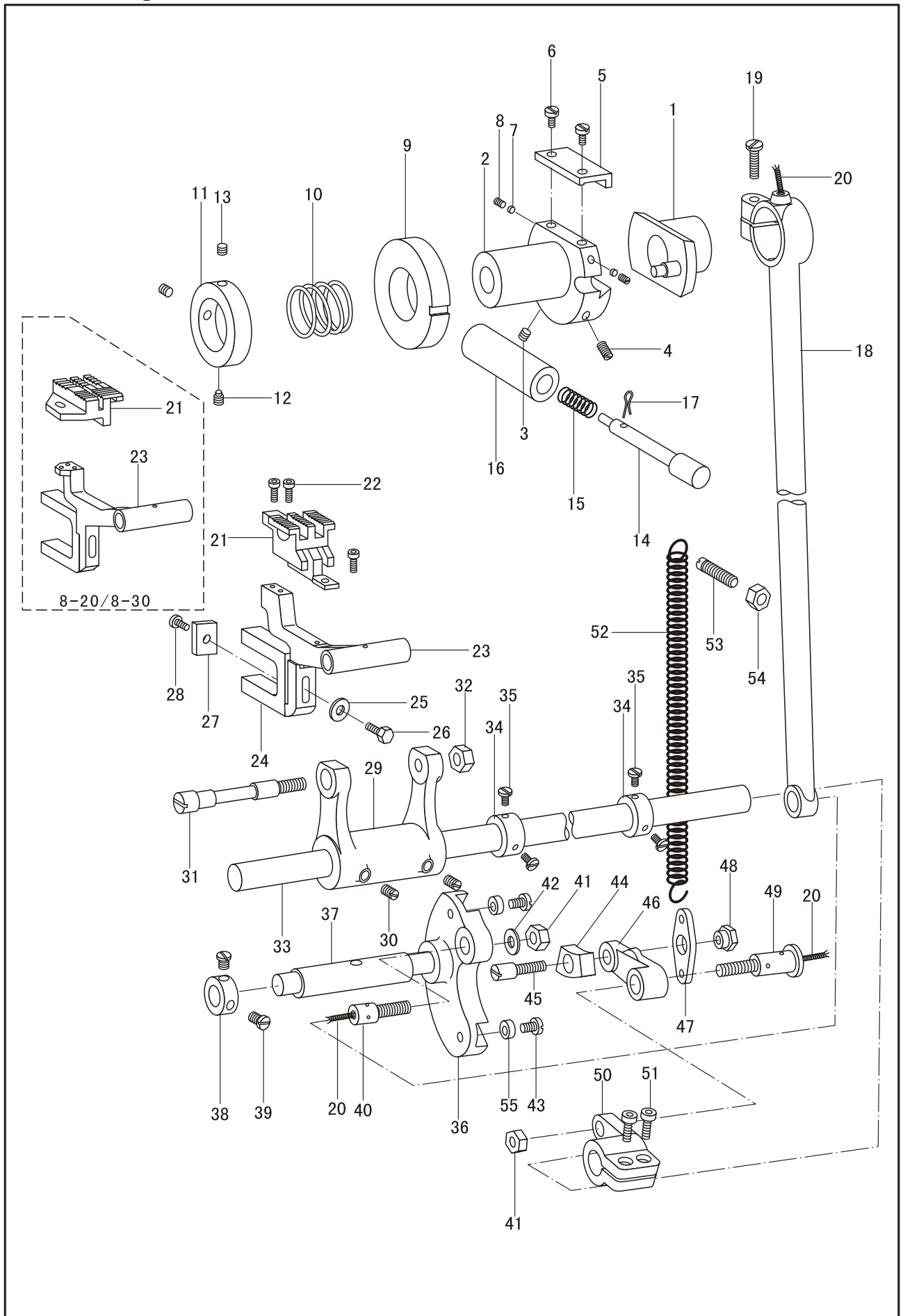

#### 4.Feed components

No.	Part No.	Name of Parts	Qty.				Remark
			28-30	8-30	28-20	8-20	
1	14KT4-001	Feed driving eccentric	1	1	1	1	
2	14KT4-002	Flange	1	1	1	1	
3	14KT4-003	Screw	1	1	1	1	SM3/16"X32X10.5
4	14KT4-004	Screw	1	1	1	1	SM3/16"X32X10.5
5	14KT4-005	Friction plate	1	1	1	1	
6	13WF3-049	Pinch screw	2	2	2	2	SM3/16"X40X11
7	13WF3-047	Linig metal	2	2	2	2	
8	22T1-011	Screw	2	2	2	2	SM11/64"X40X6
9	14KT4-006	Adjusting disc	1	1	1	1	
10	14KT4-007	Spring	1	1	1	1	
11	14KT4-008	Collar	1	1	1	1	
12	16WF1-054	Screw	1	1	1	1	SM1/4"X32X8
13	13WF1-057	Screw	2	2	2	2	SM1/4"X32X5.5
14	14KT4-009	Feed regulating stud	1	1	1	1	
15	14KT4-010	Spirng	1	1	1	1	
16	14KT4-011	Bushing	1	1	1	1	
17		Retaining spirng	1	1	1	1	GB91-86 1.6X10
18	14KT4-012	Feed drving connection	1	1	1	1	
19	16WF2-033	Screw	1	1	1	1	SM11/64"X40X14
20		Oil wick	3	3	3	3	长20mm
21	14KT4-013	Feed dog	1	-	1	-	
	18KT3-001	Feed dog	-	1	-	1	
22	14KT4-037	Screw	3	3	3	3	
23	14KT4-014	Feed bar	1	-	1	-	
	18KT3-002	Feed bar	-	1	-	1	
24	14KT4-015	Feed lifting cam fork	1	1	1	1	
25		Washer	1	1	1	1	GB97.1-85-6
26	16WF3-015	Screw	1	1	1	1	SM7/32"X32X15
27	16WF3-013	Oil felt	1	1	1	1	
28	13WF6-008	Screw	1	1	1	1	SM1/8"X40X3.3
29	14KT4-016	Feed bar crank	1	1	1	1	
30	14KT4-017	Screw	2	2	2	2	SM17/64"X24X7.5
31	14KT4-018	Feed bar hinge screw	1	1	1	1	
32	14KT4-034	Nut	1	1	1	1	SM17/64"X24
33	14KT4-019	Feed shaft	1	1	-	-	
	15KT4-001	Feed shaft	-	-	1	1	
34	16WF3-027	Collar	2	2	2	2	
35	89WF3-007	Screw	4	4	4	4	SM1/4"X32X4.5
36	14KT4-020	Feed reversing crank	1	1	1	1	
37	14KT4-021	Bushing	1	1	1	1	
38	14KT4-022	Collar	1	1	1	1	
39	16WF2-020	Screw	2	2	2	2	SM11/64"X32X6.5
40	14KT4-023	Hinge screw	1	1	1	1	SM0.309" (7.85) X20
41	14KT4-035	Nut	2	2	2	2	SM0.309" (7.85) X20
42		Washer	1	1	1	1	GB93-87 8
43	7KT5-046	Screw	2	2	2	2	SM3/16"X32X11
44	14KT4-025	Slide block	1	1	1	1	
45	14KT4-026	Hinge screw	1	1	1	1	SM15/64"X28X10
46	14KT4-027	Feed reversing link	1	1	1	1	
47	14KT4-028	Connecting link	1	1	1	1	
48	14KT4-029	Nut	1	1	1	1	SM15/64"X28
49	14KT4-030	Hinge screw	2	2	2	2	
50	14KT4-031	Feed crank	1	1	1	1	
51	7KT1-003	Screw	2	2	2	2	M6X1X20
52	14KT4-032	Spring	1	1	1	1	
53	14KT4-033	Spring Holder	1	1	1	1	
54	21WF2-046	Nut	1	1	1	1	SM5/16"X24
55	14KT4-036	Eccentric cam	2	2	2	2	

# 5.Hook components

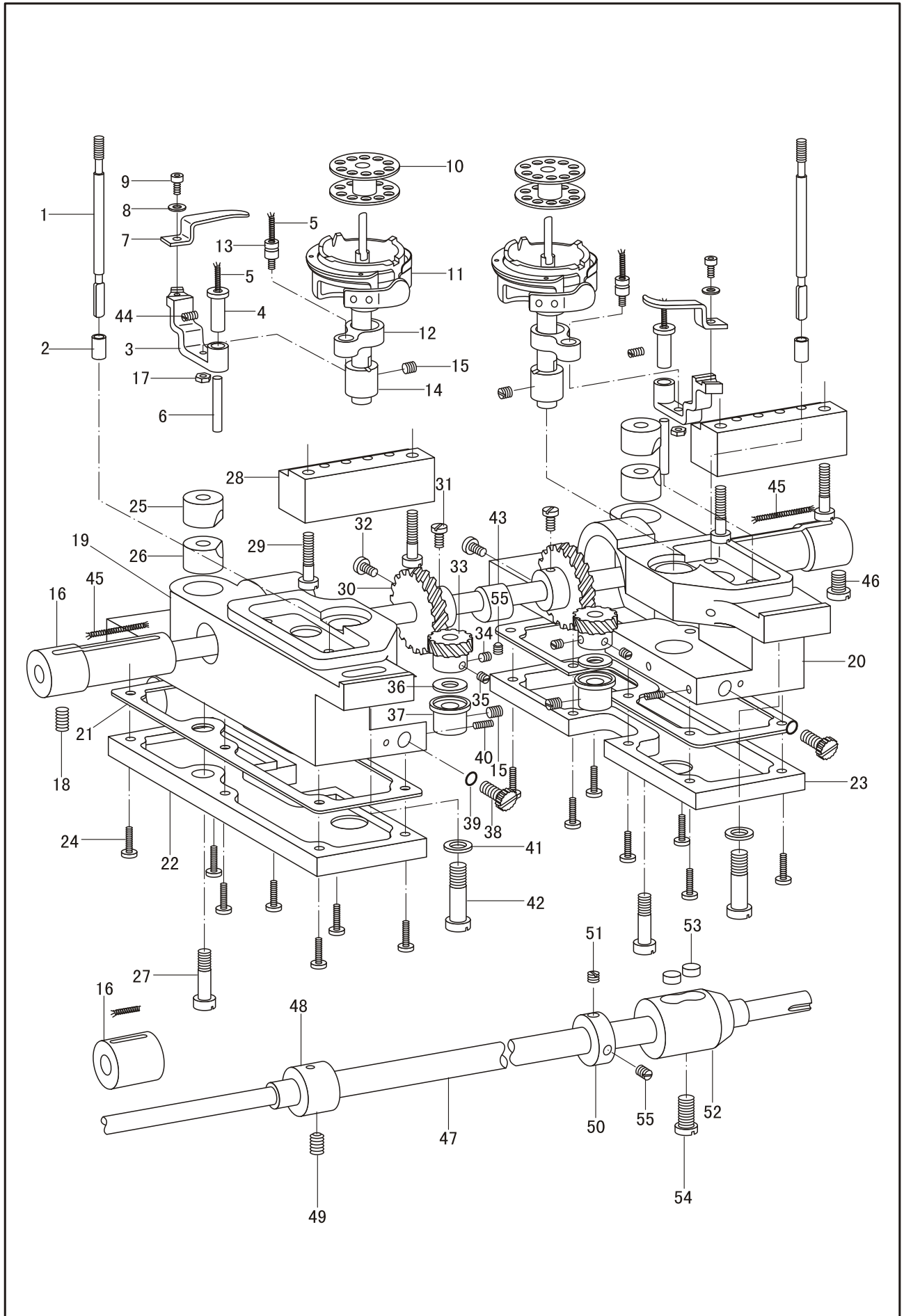

## 5.Hook components

No.	Part No.	Name of Parts	Qty.				Remark
			28-30	8-30	28-20	8-20	
1	88WF2-031	Oil gauge	2	1	2	1	
2	88WF2-020	Oil gauge guide	2	1	2	1	
3	14KT5-002	Bobbin case opener lever	2	1	2	1	
4	14KT5-003	Hinge stud	2	1	2	1	
5		Oil wick	4	2	4	2	φ5X10
6	88WF2-019	Oil tube	2	1	2	1	
7	14KT5-004	Bobbin case opener	2	1	2	1	
8		Washer	2	1	2	1	GB848-85-3
9	13WF1-015	Screw	2	1	2	1	M3X0.5X6
10	14KT5-005	Bobbin	2	1	2	1	
11	14KT5-006	Hook	2	1	2	1	
12	14KT5-007	Bobbin case opener link	2	1	2	1	
13	14KT5-019	Roller	2	1	2	1	
14	14KT5-008	Bushing	2	1	2	1	
15	16WF3-032	Screw	4	2	4	2	SM7/32"X32X5.5
16	14KT5-009	Bushing(L)	2	1	2	1	
	18KT4-001	Bushing(L)	-	1	-	1	
17	22WF4-044	Nut	2	1	2	1	SM11/64"X40
18	6K1-041	Screw	1	1	1	1	SM5/16"X24X12.5
19	14KT5-010	Left hook saddle	1	-	1	-	
20	14KT5-011	Right hook saddle	1	1	1	1	
21	88WF2-029	Gasket	2	1	2	1	
22	88WF2-028	Oil reservoir(L)	1	-	1	-	
23	88WF2-032	Oil reservoir(R)	1	1	1	1	
24	22T7-015	Screw	14	7	14	7	SM9/64"X40X11
25	88WF2-034	Collar (upper)	2	1	2	1	
26	88WF2-035	Collar (lower)	2	1	2	1	
27	1WF2-060	Screw	2	1	2	1	SM15/64"X28X32
28	14KT5-012	Block	2	1	2	1	
29	14KT5-013	Screw	4	2	4	2	SM7/32"32X21
30	16WF1-052	Hook driving gear	2	1	2	1	
31	14KT5-020	Screw	2	1	2	1	SM1/4"X40X9
32	14KT5-021	Screw	2	1	2	1	SM1/4"X40X8
33	88WF2-021	Hook driving pinion	2	1	2	1	
34	21WF1-033	Screw A	2	2	2	2	SM1/4"X40X5.5
35	21WF1-043	Screw B	2	1	2	1	SM1/4"X40X4.5
36	1WF2-077A	Washer	2	1	2	1	
37	88WF2-018	Bushing(lower)	2	1	2	1	
38	88WF2-027	Oil regulating dial	2	1	2	1	
39	17WF5-021	Dial ring	2	1	2	1	
40	16WF3-038	Screw	2	1	2	1	SM1/8"X40X8
41	8WF2-005	Washer	2	1	2	1	
42	14KT5-018	Screw	2	1	2	1	SM17/64"X24
43	88WF5-003	Feed lifting cam	1	1	1	1	
44	22WF5-025	Screw	2	1	2	1	SM7/32"X32X11
45		Oil wick	2	1	2	1	长90mm
46	7KT4-024	Screw	1	1	1	1	SM17/64"X32X17.5
47	14KT5-014	Lower shaft	1	1	-	-	
	15KT5-001	Lower shaft	-	-	1	1	
48	14KT5-015	Bushing(middle)	1	1	1	1	
49	16WF1-053	Screw	1	1	1	1	SM1/4"X32X7
50	16WF3-027	Collar	1	1	1	1	
51	89WF3-007	Screw	1	1	1	1	SM1/4"X32X4.5
52	14KT5-016	Bushing(right)	1	1	1	1	
53	16WF1-025	Oil felt	2	2	2	2	φ17X10
54	14KT5-017	Screw	1	1	1	1	SM17/64"X32X13
55	16WF1-047	Screw	2	2	2	2	SM1/4"X32X5.5

## 6.Thread tension components

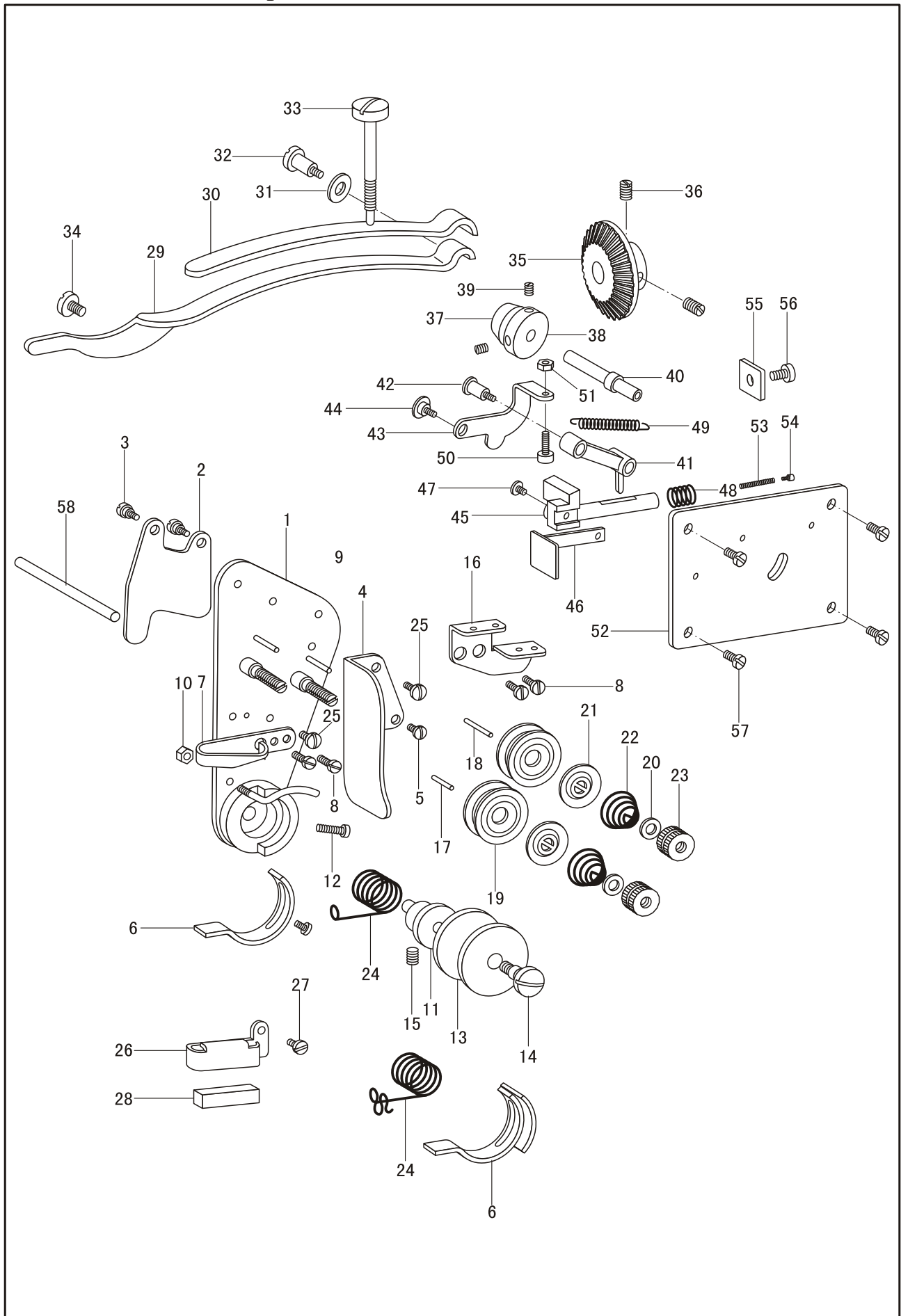

## 6.Thread tension components

No.	Part No.	Name of Parts	Qty.				Remark
			28-30	8-30	28-20	8-20	
1	14KT6-001A	Tension barcket CPL.	1	-	1	-	
	18KT5-001G	Tension bracket CPL.	-	1	-	1	
2	14KT6-001B	Tensio9n release lever	1	-	1	-	
	18KT5-001A	Tension release lever	-	1	-	1	
3	16WF2-046A15	Screw	2	2	2	2	SM9/64"X40X2.5
4	14KT6-001D	Covering plate	1	1	1	1	
5	16WF2-050	Screw	1	1	1	1	SM9/64"X40X6
6	14KT6-001C	Thread controller spring stop	1	-	1	-	
	18KT5-001B	Thread controller sprng stop	-	1	-	1	
7	14KT6-001E	Thread guide	1	1	1	1	
8	21WF1-037	Screw	4	4	4	4	SM9/64"X40X4
9	14KT6-001F	Thread guide (lower)	1	-	1	-	
	18KT5-001F	Thread guide (lower)	-	1	-	1	
10	21WF3-017	Nut	1	1	1	1	SM1/8"X40
11	14KT6-001G	Thrad controller spring stud	1	1	1	1	
12	13WF2-047	Screw	1	1	1	1	SM11/64"X32X9
13	14KT6-001H	Thread controller disc	2	1	2	1	
14	14KT6-001I	Thread controller stud	1	-	1	-	
	18KT5-001C	Thread controller stud	-	1	-	1	
15	49WF4-029	Screw	1	1	1	1	SM11/64"X32X4
16	14KT6-001J	Thread guide	1	-	1	-	
	18KT5-001D	Thread guide	-	1	-	1	
17	14KT6-001K	Tension release pin(short)	1	1	1	1	
18	14KT6-001L	Tenion release pin(long)	1	-	1	-	
19	14KT1-011C	Tension disc	4	2	4	2	
20	14KT6-001M	Washer	2	1	2	1	
21	14KT6-001N	Tension release disc	2	1	2	1	
22	14KT6-001P	Tension spring	2	1	2	1	
23	14KT6-001Q	Tension nut	2	1	2	1	
24	14KT6-001R	Tension controller spring	1	-	1	-	
	18KT5-001E	Tension controller spring	-	1	-	1	
25	16WF2-020	Screw	2	2	2	2	SM11/64"X32X6.5
26	16WF2-013	Thread guide	1	-	1	-	
27	16WF2-015	Screw	1	-	1	-	SM9/64"X40X6.5
28	16WF2-014	Felt	1	-	1	-	
29	14KT6-002	Presser bar spring(flat)	1	1	1	1	
30	14KT6-003	Presser bar spring(auxiliary)	1	1	1	1	
31		Washer	1	1	1	1	GB97.1-85-8
32	14KT6-004	Screw	1	1	1	1	
33	14KT6-005	Regulating screw	1	1	1	1	
34	14KT1-010	Screw	1	1	1	1	
35	14KT6-006	Bobbin winder driving gear	1	1	1	1	
36	22T2-005B3	Screw	2	2	2	2	SM1/4"X40X7
37	14KT6-007A	Friction roller	1	1	1	1	
38	14KT6-007B	Friction roller base	1	1	1	1	
39	13WF6-018	Screw	2	2	2	2	SM11/64"X40
40	14KT6-007C	Bobbin winder shaft	1	1	1	1	
41	14KT6-007D	Bobbin winder link	1	1	1	1	
42	14KT6-007E	Screw	1	1	1	1	
43	14KT6-007F	Connecting plate	1	1	1	1	
44	14KT6-007G	Screw	1	1	1	1	
45	14KT6-007H	Bobbin winder release lever	1	1	1	1	
46	14KT6-007I	Bobbin winder set lever	1	1	1	1	
47	6KT2-022	Screw	1	1	1	1	M4X5
48	14KT6-007J	Reset spring	1	1	1	1	
49	14KT6-007K	Reset spring	1	1	1	1	
50	14KT6-007L	Screw	1	1	1	1	GB6170-86 M4
51		Locking nut	1	1	1	1	
52	14KT6-007M	Bobbin winder bracket	1	1	1	1	
53	14KT6-007N	Spring	1	1	1	1	
54	14KT6-007O	Stop stud	1	1	1	1	
55	14KT6-007P	Stopper	1	1	1	1	
56	16WF1-059	Screw	1	1	1	1	SM11/64"X40X6
57	13WF2-047	Screw	4	4	4	4	SM11/64"X32X9
58	14KT6-008	Tension release pin	1	1	1	1	

## 7. Accessories

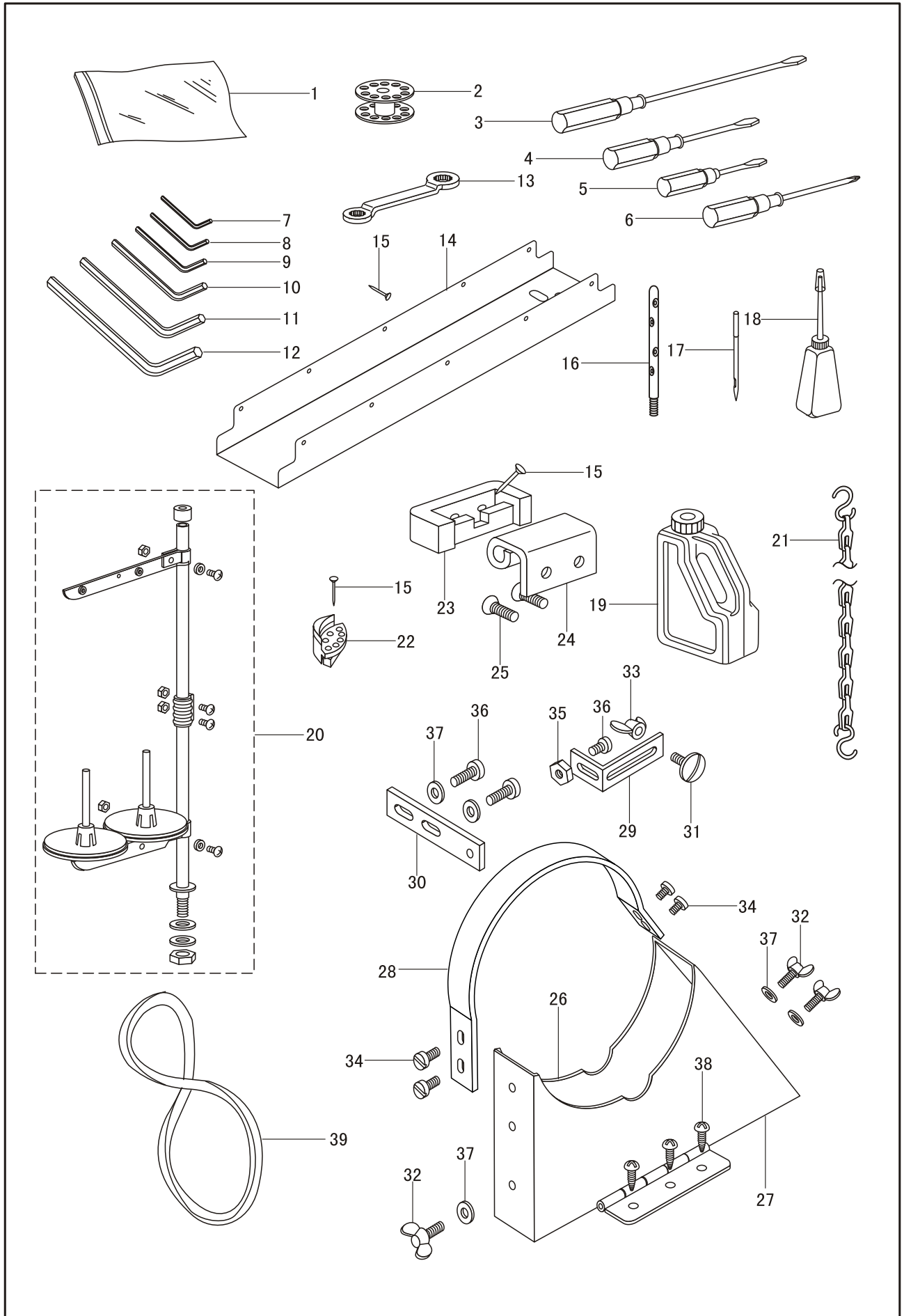

## 7. Accessories

No.	Part No.	Name of Parts	Qty.				Remark
			28-30	8-30	28-20	8-20	
1	33TF-010	Parts bag	1	1	1	1	
2	14KT5-005	Bobbin	12	5	12	5	
3	33TF-012	Screwdriver (big)	1	1	1	1	
4	33TF-013	Screwdriver (middle)	1	1	1	1	
5	33TF-014	Screwdriver (small)	1	1	1	1	
6	35WF6-002	Screwdriver (middle)	1	1	1	1	
7		Allen key	1	1	1	1	S=1/16"
8		Allen key	1	1	1	1	S=2mm
9	1F-010	Allen key	1	1	1	1	S=2.5mm
10	1F-011	Allen key	1	1	1	1	S=3mm
11		Allen key	1	1	1	1	S=4mm
12		Allen key	1	1	1	1	S=5mm
13		Wrench	1	1	1	1	10X11
14	14KT7-001	Drip pan	1	1	-	-	
	15KT6-001	Drip pan	-	-	1	1	
15	33TF-004	Nail	17	17	17	17	SG162-79 L=22
16	14KT1-017	Thread guide pin	1	1	1	1	
17	14KT3-038	Needle	6	3	6	3	DYX3 24~26#
18	33TF-011	Oil pot	1	1	1	1	
19	1F-012	Oil tank	1	1	1	1	
20	1F-014	Thread stand	1	-	1	-	
	4F-007	Thread stand	-	1	-	1	
21		Chain	1	1	1	1	
22	3KT2-004	Vibration free pad	4	4	4	4	
23	22T9-007F2	Machine hinge cushion	3	3	3	3	
24	60WF6-006	Machine hinge	3	3	3	3	
25	3KT2-002	Screw	6	6	6	6	SM17/64"X32X7.5
26	14KT7-002A	Belt guard CPL (Left)	1	1	1	1	
27	14KT7-002B	Belt guard CPL (Right)	1	1	1	1	
28	14KT7-002C	Belt guard	1	1	1	1	
29	14KT7-002D	Supporting plate	1	1	1	1	
30	14KT7-002E	Supporting plate	1	1	1	1	
31	14KT7-002F	Screw	1	1	1	1	SM7/32"X32X9
32	14KT7-002G	Screw	3	3	3	3	M5
33	14KT7-002H	Nut	1	1	1	1	SM7/32"X32
34	14KT7-002I	Screw	4	4	4	4	SM13/64"X32X9
35		Washer	1	1	1	1	GB6170-86 M5X12
36		Screw	3	3	3	3	GB818-85 M5X12
37			5	5	5	5	GB97.2-85-5
38			3	3	3	3	GB845-85 ST6X22
39		V-belt	1	1	1	1	A1372